

COLD NEUTRON SOURCE SUPERCRITICAL, VARIABLE SPEED, MAGNETIC BEARING CIRCULATOR

W. D. Batton¹ J. E. Dillard¹, T. Lucas², K. T. Sundset³

¹Barber-Nichols Inc.
Arvada, Colorado, 80002, USA

²HIFR/SNS, ORNL
Oak Ridge, Tennessee 37830, USA

³Revolve Magnetic Bearings, Inc.
Calgary, Alberta, T2R 0B3, Canada

ABSTRACT

Intense beams of cold neutrons are used to investigate how materials are assembled at the atomic level. The neutrons are passed through a moderator vessel cooled with hydrogen. One such system under construction at ORNL starts operation at room temperature then cools the hydrogen loop down to the operating point of 17K. To avoid the liquid to vapor phase changes the system operates supercritical at 15 bar pressure. The hydrogen prime mover is a centrifugal cryogenic circulator that operates over the entire temperature range. This wide temperature (and corresponding density range) requires wide speed variation in the circulator to maintain the correct moderator cooling flow. Additionally, a requirement for high efficiency at the low temperature normal operating point requires high overall operating speed. The solution to this wide operating range and high efficiency requirement is a circulator that operates continuously between the speeds of 60,000 rpm and 15,000 rpm. Magnetic bearings were selected to make the wide speed range and high speed operation practical and reliable. The resulting design provides 4.15 liters per minute of 288K hydrogen with a 0.27 bar pressure rise (60,000 rpm) and achieves a flow rate of 1.02 liters per minute of 20K hydrogen with 1.0 bar pressure rise at the normal operating condition (15,000 rpm).

INTRODUCTION

The 'High Flux Isotope Reactor' (HFIR) is a research facility situated at the Oak Ridge National Laboratory. It is presently undergoing a major upgrade program, which includes the installation of a cold source system for the production of cold neutron beams. A particle accelerator based facility, called the 'Spallation Neutron Source' (SNS) is also under construction at Oak Ridge. This will provide very high intensity pulsed beams of cold and thermal neutrons. Both systems cool the neutrons by passing them through a bath of cold (17 K) hydrogen. This hydrogen must be circulated through the bath and then to a refrigeration system that removes the heat picked up from the neutrons (and other system heat sources). Since a cycle of operation begins with the system at ambient temperature followed by initial cool down, then

cooled to the normal operating temperature of 17 K, the hydrogen circulator must operate with widely varying volume flow rates and fluid densities. A centrifugal circulator that operates over a very wide speed range can best satisfy this wide operating range. This wide speed range would not normally be possible due to shaft dynamics and critical shaft speeds that would be encountered. These operational problems are magnified by the fact that the cold impeller must be thermally isolated from the warm motor and bearings which is only possible by the use of a cantilevered extended shaft.

An additional consideration is that the circulator must possess very high reliability. In the HIFR system, a circulator failure could potentially jeopardize the integrity of the moderator vessel that is being cooled. Should heating damage the vessel, it would have to be removed from the reactor, a very expensive operation.

These requirements can best be satisfied through the use of magnetic bearings. In particular, the use of magnetic bearings that dynamically determine the shaft position (orbit) and that can continuously correct the bearing forces to maintain shaft stability solves the wide operating range. Furthermore, these bearings, with no mechanical contact with the shaft, will have very long life expectancy limited only by the life of the electronics and electrical components.

A circulator with magnetic bearings has been designed and is now being fabricated. This circulator is a result of the combined efforts of Oak Ridge National Laboratory (the circulator requirement specifier and circulator end user), Revolve Magnetic Bearings, Inc (supplier of the bearings and motor), and Barber-Nichols Inc (circulator designer and system integrator).

WHY COLD NEUTRONS ARE USED

Neutrons have a mass very close to that of protons, but with the absence of a polarizing charge they have unique applications. At low energy they are used for magnetic and polymer studies in addition to supporting a rapidly growing industrial base such as 'actual operating' stress analysis on operating turbine blades and solid-state physics. Some applications favor highly defined pulses of low energy (or cold) neutrons, as provided by a spallation source, while others are more suited to the continuous and broader energy spectrum of neutrons from a reactor. In both cases, however high cross-section hydrogenous materials are used to cool (or energy moderate) the high and thermal energy neutrons to appropriate levels.

SITES WHICH WILL USE THE CIRCULATOR

High Flux Isotope Reactor (HFIR) Cold Source

A reactor remains critical by continuously producing neutrons to maintain a chain reaction. However, in a research reactor some of these neutrons are channeled away by beam lines for research functions. For many research areas these neutrons are significantly more useful if they

are moderated (cooled). Various hydrocarbons, or frequently hydrogen itself at cryogenic temperatures as is the case with both the HFIR and SNS systems, are normal materials for a moderator. Within this moderator, neutrons experience many collisions with the low temperature hydrogen nuclei and consequently lose energy. The beam line directly views the moderator surface and allows the cold neutrons to exit to the research facility. Heat generated in the hydrogen as a result of energy exchange is removed by a heat exchanger (moderator containment vessel) that interfaces the flowing hydrogen with a cryogenic helium refrigerant loop.

The moderator containment vessel is made from 6061 aluminum, which is relatively transparent to neutrons but, nonetheless, generates two thirds of the total heat load of about 2.6 kW. Since heat transfer with the vessel is a function of flow, the hydrogen circulator is a vital component in the system. To eliminate any chance of boiling in the moderator vessel, the hydrogen is kept above its critical pressure of about 13 bar abs by a gas handling system. It is cooled to 17K in the heat exchanger and at a flow of 1 l/s, returns at approximately 21K. The loop pressure drop under these conditions is 1 bar.

When a reactor is shutdown there is a period of residual heat, which could quickly destroy the moderator vessel if it were not actively cooled. Consequently, an emergency cooling system is provided using liquid nitrogen as a coolant in place of the refrigerator. However, at this warmer temperature and higher fluid density, maintaining adequate heat transfer requires higher hydrogen flow rates. Even higher flow rates significantly advantage cool-down times, especially if the flow is maximized when the gas is at ambient temperature. There are also many potential fault condition situations that are capable of producing high peak pressures or transients. Computer models indicate that potentially serious effects resulting from these transients are greatly tempered by the ability to make rapid and responsive changes in hydrogen flow.

Spallation Neutron Source (SNS)

A spallation source produces neutrons as a result of the collision of pulsed high-energy protons with a heavy material target, such as tungsten, tantalum or in the case of the SNS, circulating mercury. The intense neutron pulses can attain higher peak brightness levels than would be possible with a reactor, though the pulsed beam structure usually results in a lower overall integrated flux. Neutrons are produced over a broad energy spectrum and are subsequently moderated in the same way as with a reactor. The nature of a spallation source does not produce long term residual heating. However, other problems such as lower flux stability that result in rapid heat load changes can be mitigated through the ability to provide flow changes in response to fluid density.

The SNS is a new, major program at Oak Ridge National Laboratory. The SNS program is a collaborative effort with six of the national laboratories taking part. Overall, this is a \$1.5 to \$2 billion dollar program. The project is slated to be operational by 2005.

CIRCULATOR CONCEPT

The design of the circulator began with an initial study to find the best manner to meet the specifications and provide the reliability and life desired.

The prospect of varying the flow of hydrogen in direct proportion to its fluid density prompted a comprehensive design study by Barber Nichols. This study demonstrated that with high overall rotational speeds, desired parameter variances could be achieved using rotational speed changes only. However speeds up to 60,000 rpm are beyond the limit of conventional grease packed bearings so magnetic bearing technology was examined. This resulted in a circulator design capable of the required speeds between 15,000 and 60,000 rpm allowing a factor of four in the variance in volumetric flow-rate. In practice, the developed head across the circulator will be constantly monitored and used to initiate corresponding speed changes of the pulsed DC motor. A total of five circulators are planned, three for the HFIR facility and two for the SNS. One circulator provides the required total flow, but since high reliability is paramount, prevailing wisdom dictates that the installation of spare units is prudent.

The pumping element was designed in conjunction with the magnetic bearing supplier to allow the unit to perform at all of the speeds from 15,000-60,000 rpm. Barber-Nichols, as the system integrator, has the responsibility to design all of the external motor housings, motor shaft and extension, the pump impeller and housing. Revolve Magnetic Bearings designed and built the drive motor and controller as well as the magnetic bearings and their controller.

DRIVE SPINDLE (MOTOR AND BEARINGS)

The drive spindle is supplied by Revolve Magnetic Bearings Incorporated (Revolve), an SKF company. The spindle consists of two 265 N (60 pound) radial magnetic bearings and one 220 N (50 pound) thrust magnetic bearing with a brushless DC, 900 W motor that can deliver up to 810 Watts (1.086 hp) of mechanical power. The motor rotor, with an outside diameter of approximately 48 mm (1.890 inches), is integral with the shaft providing a very efficient solution and allowing for accurate continuous speed control from 0 to 1000 Hz (60,000 RPM) with an available torque of 0.24 N-m (2.124 in-lb). The overhung design allows for minimal heating of the hydrogen by the shaft and magnetic bearing components, a key component in the operation and performance in supercritical hydrogen. As well, the overhung design substantially simplifies the housing design for the magnetic bearing components. The approximate rotor weight, including the impeller, is 3.7 kg (8 pounds) with a bearing span of 116 mm (4.55 inches).

The backup auxiliary bearings are a customized configuration designed by Revolve and manufactured by SKF and are located both at the drive end and non-drive end of the machine, outboard of the radial position sensors. Each bearing arrangement consists of a full compliment angular contact pair with ceramic balls and coated with molybdenum disulfide (MOS₂) and has been designed to survive five drops from full speed (1000 Hz or 60,000 RPM).

CONTROL HARDWARE

The MB350 digital control system is a standard product offered by Revolve and is designed for low power applications of magnetic bearings. For this application there is full digital control for five axes of movement. This is accomplished through position sensing inputs from the five axes: two radial axes on the drive end, two radial axes on the non-drive end, and one thrust axis located at the non-drive end outboard from the radial bearing. The signal processing allows for output currents to be commanded for the ten amplifiers for bi-directional control on each of the five axes.

The MB350 includes integrated motor control from a 600W, international source power supply. An additional Auxiliary Power Unit (APU) is supplied providing, along with the MB350, a total of 900 Watts of power to the motor. The motor control can receive its speed set point digitally from the front panel of the controller or the speed set point can be supplied by an analog 0-10V or 4-20mA signal by the customer. An RS-485 (EIA485) remote serial connection has been implemented in the MB350 to allow connection of a remote computer to the system. The connection provides the remote computer with several functions, such as run, stop, and speed changes, as well as monitoring of status information such as speed, shaft position, and alarm status.

An additional feature of the MB350 is regenerative power circuitry, turning the motor into a generator with sufficient capacity to power the magnetic bearings for levitated coast down to approximately 25% of full speed (250 Hz or 15,000 RPM).

CIRCULATOR DESIGN

Since Barber-Nichols was tasked with supplying the design that meets the hydrogen pressure and flow requirements as well as meet the rigorous needs of a nuclear environment a complete review of the Barber-Nichols design was accomplished by ORNL personnel.

The circulator was required to meet four points of a design envelope. These points spanned temperatures from 288K to 17K with required flow rate changes of 5 to 1 liters per second respectively. The inlet pressure is kept at 14 bar abs keep the fluid super critical. To meet the above conditions a partial emission pump design running at speeds from 60,000 rpm at ambient temperatures to 15,000 rpm at 17K satisfies all the performance goals. This design was made more difficult since the heat leak to the hydrogen had to be kept low which dictates an extended shaft between the motor and pump. The long shaft initiates shaft dynamics problems. The motor and magnetic bearings were designed with the shaft and impeller as part of the system to keep the system operating 20 percent below the first critical speed of the shaft. This is made possible by the dampening afforded by the magnetic bearings.

The result of this design is shown in the figure below. This design meets all of the criteria, low conductive heat leak (26 watts), meets all head and flow specifications, and provides long life and high reliability.

**COLD NEUTRON SOURCE SUPERCRITICAL,
VARIABLE SPEED, MAGNETIC BEARING CIRCULATOR**

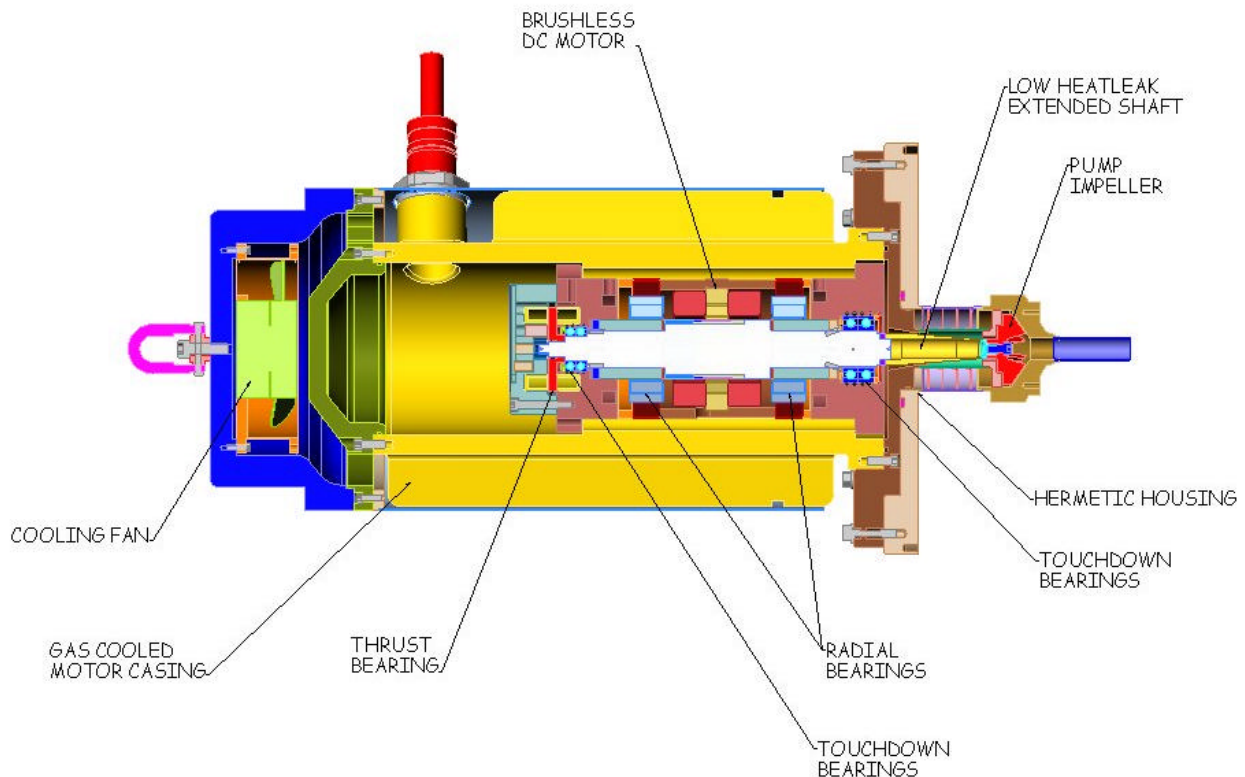

CONCERN ABOUT HYDROGEN EMBRITTLEMENT

Since the inside of the motor and pump are constantly blanketed by hydrogen all materials of construction were investigated for susceptibility to embrittlement. The stationary components are either aluminum, which is not affected by embrittlement or carbon steel motor stator lamination which are in compression and under very low stress.

The greatest problems were associated with the rotating assembly (impeller, extended shaft, motor shaft, and thrust bearing). These components were chosen to be made from materials not affected by hydrogen embrittlement but difficulties were associated with the shaft and thrust disc which must be made from magnetic materials. AISI 4140 was chosen for these parts since it has been used in many pumps where hydrogen sulfide (a more reactive form of hydrogen) was present. The 4140 is kept in a heat treated form which is less susceptible to embrittlement. The only difficulty being the interface of the 4140 with the 300 series stainless

extended shaft. During welding carbides can form in the heat affected zone. It was determined that an Invar ring placed between the two materials and welded to both would prevent the formation of carbides at either interface.

ASSEMBLY & TESTING

The pump assembly will go through rigorous testing before, during and after assembly. The tests will include weld joint certification, approval of weld procedures, welder qualifications and inspection of the welds by certified inspectors. The outer pressure shell will be hydrostatically tested to 28 bar followed by a leak test. The units will then be assembled in their final form and tested on ambient air to obtain head versus flow data over the operating speed range. After successful completion of these tests the pump end will be submerged in LN₂ and spin tested to assure cold functionality.

The pump data that is obtained will be plotted in a non-dimensional format that will show the operation on hydrogen at different temperatures and different shaft speeds.

SUMMARY

Currently the circulators are being manufactured at Barber-Nichols and will be under test in the fourth quarter of 2001. The pump housings have been delivered to the cryogenic system manufacturer to be welded into the vacuum jacketed pump box.

At this time the design is complete, manufacturing of the housings is nearly finished and the shaft weld samples are in process. The shafts and motor housings will be shipped to Revolve for installation of the motor and magnetic bearings as well as tuning the electronics prior to returning the completed rotating assemblies to Barber-Nichols for final assembly and testing.

This program has gone along smoothly considering the number of groups and people involved in the design. This circulator is intended to be the first in a line of magnetic bearing cold pumps and compressors for use in applications where long life and high reliability is desired.